

# **KDFX 6020**

**Montageanweisungen  
Assembly instructions  
Instructions de montage  
Montageinstructies  
Istruzioni di montaggio**



**FOR THE WAY IT'S MADE.® \***



## D

Wichtige Hinweise:

1. Alle Maßangaben in Millimeter
2. Während der Montage muss der Netzstecker gezogen sein.
3. Geschirrspüler nur im eingebauten Zustand betreiben.
4. Achtung bei unebenen Aufstellflächen: Geschirrspüler mit weit herausgedrehten Füßen vorsichtig unter Arbeitsplatte schieben.
5. Wenn das Gerät am Ende einer Küchenzeile steht und damit eine Seitenwand zugänglich ist, muss der Scharnierbereich seitlich verkleidet sein (Abdeckung beim Service erhältlich).
6. Schnittkanten an Möbelteilen und Arbeitsplatten müssen gegen Feuchtigkeit isoliert werden (Isoliermaterial nicht im Lieferumfang enthalten).
7. Zwischenräume zu Nachbarmöbeln und Arbeitsplatte dürfen nicht versiegelt werden (z.B.Silicon)
8. Zwischen Oberkante Holztür und Arbeitsplatte muß ein Spalt von min.3 mm sein.
9. Beim Einsatz von Elektroschraubern ist eine niedrige Drehzahl einzustellen.
10. Der Inhalt des Beipacks kann je nach Geräteausführung unterschiedlich sein. ★
11. Bei der ersten Inbetriebnahme den Wasserzulauf und Wasserablauf auf Dichtheit prüfen.
12. Nach der Dekorplatten- und Sockelmontage ist vor dem Öffnen der Tür zu prüfen ob bzw. wie weit der Sockel auszuschneiden ist (siehe Seite 25-26) um Beschädigungen zu vermeiden.
13. Vorsicht! Verletzungsgefahr durch scharfe Kanten.
14. Das Gerät mit neuen Schläuchen an die Wasserversorgung anschließen. Keine alten Schläuche wiederverwenden.
15. Je nach Geräteausführung wird das Magnetventil des Zulaufschlauches durch die Netzspannung ausgelöst (siehe ★ ★).

## GB

Important notes:

1. All sizes are given in millimetres.
2. During assembly, unplug the appliance from the mains.
3. Do not use the dishwasher until it has been fully assembled.
4. Be careful about irregular surfaces: regulate the foot height push the dishwasher under the worktop!
5. When installing the dishwasher at the end of a fitted kitchen and the side of the machine is left exposed, cover the hinge area (available from the After-Sales Service).
6. Protect the edges of units and worktops from humidity (insulating material not supplied).
7. Do not seal the gaps between the appliance and adjacent units/worktop (for example, with silicone).
8. Leave at least 3 mm between the top edge of the wooden panel and the worktop.
9. Set any electrical screwdrivers to a low rev count.
10. Depending on the model, your dishwasher may differ slightly from the illustration. ★
11. The first time you use the dishwasher, check the water inlet hose and drain hose for leaks.
12. Once the decor panels and plinth have been fitted, before opening the dishwasher door, evaluate whether the plinth needs to be trimmed, and if so by how much, (see page 25-26), in order to avoid damaging it.
13. Caution! Beware of sharp corners.
14. The Appliance is to be connected to the water supply using new hose-sets. Old hose-sets should not be reused.
15. Depending on Appliance configuration the magnet valve of inlet will be driven by line voltage (see ★ ★).

**F**

Remarques importantes :

1. Toutes les dimensions sont exprimées en millimètres.
2. Durant le montage, la fiche doit être débranchée de la prise secteur.
3. Mettez le lave-vaisselle en marche uniquement après avoir terminé le montage.
4. Attention lorsque la surface de l'emplacement n'est pas plane : régler la hauteur des pieds. Glisser le lave-vaisselle au-dessous du plan de travail.
5. Si le lave-vaisselle est installé à l'extrémité d'une cuisine à éléments, avec la paroi latérale accessible, la zone des charnières doit être revêtue (le revêtement est disponible auprès du Service Assistance).
6. Isolez contre l'humidité les bords des meubles et des plans de travail (le matériau isolant n'est pas fourni).
7. Les jeux et écarts entre le lave-vaisselle et les meubles adjacents ou le plan de travail n'ont en aucun cas à être obturés (par exemple, à l'aide de silicone).
8. Prévoyez un espace minimum de 3 mm entre l'angle supérieur du panneau en bois et le plan de travail.
9. Si vous employez un tournevis électrique, sa vitesse de rotation doit être réglée sur une vitesse peu élevée.
10. Le contenu de l'emballage peut être différent en fonction du modèle de lave-vaisselle. ★
11. Lorsque vous utilisez le lave-vaisselle pour la première fois, vérifiez l'étanchéité de l'alimentation en eau et de la vidange.
12. Après avoir monté les panneaux décoratifs et le socle et avant d'ouvrir la porte, vérifiez s'il convient de découper le socle (voir page 25-26) pour éviter d'endommager la porte.
13. Attention! Risques de blessures à cause de la présence d'arêtes vives. Soyez très prudents dans la manipulation de l'appareil durant son installation.
14. L'appareil doit être raccordé à l'arrivée d'eau en utilisant des séries de tuyaux neufs. Évitez de réutiliser des séries de tuyaux usagés.
15. Selon la configuration de l'appareil, l'électrovalve du tuyau d'alimentation sera actionnée par la tension de ligne (voir ★ ★).

**NL**

Belangrijke opmerkingen:

1. Alle maten zijn aangegeven in millimeter.
2. Tijdens de montage moet de stekker uit het stopcontact gehaald zijn.
3. Gebruik de afwasmachine pas nadat de montage voltooid is.
4. Let op als de vloer niet vlak is: schuif de vaatwasser met ver uitgedraaide voeten voorzichtig onder het aanrecht!
5. Als de afwasmachine wordt geïnstalleerd aan het uiteinde van een aanbouwkeuken waarbij een van de zijwanden zichtbaar blijft, moet het gebied met de scharnieren zijdelings worden bekleed (afdekking verkrijgbaar bij de Klantenservice).
6. Bescherm de randen van de meubels en werkbladen tegen vocht (het isolatiemateriaal is niet inbegrepen in de levering).
7. Dicht de ruimten tussen het apparaat en de aangrenzende meubels/het werkblad niet af (b.v. met silicone).
8. De afstand tussen de bovenste rand van het houten paneel en het werkblad moet minimaal 3 mm zijn.
9. Als er een elektrische schroevendraaier wordt gebruikt, moet deze op een laag toerental worden ingesteld.
10. De inhoud van de verpakking kan verschillen al naargelang het model afwasmachine. ★
11. Controleer bij het eerste gebruik de afdichting van de watertoevoer en -afvoer.
12. Na de montage van de decoratieve panelen en van de plint, dient u, alvorens de deur te openen, te controleren of en hoeveel de plint moet worden bijgesneden (zie pagina 25-26), om beschadiging van de deur te voorkomen.
13. Let op! Gevaar voor verwondingen door scherpe randen.
14. Het apparaat moet op de watertoevoer worden aangesloten met een nieuwe set slangen. Gebruik oude sets slangen niet opnieuw.
15. Afhankelijk van de configuratie van het apparaat wordt de magneetklep van de toevoerslang aangedreven door de netspanning (zie ★ ★).

## I

### Note importanti:

1. Tutte le dimensioni sono indicate in millimetri.
2. Durante il montaggio, la spina deve essere staccata dalla presa di corrente.
3. Azionare la lavastoviglie solo a montaggio completato.
4. Attenzione alle superfici irregolari! Regolare adeguatamente l'altezza dei piedini. Spingere la lavastoviglie sotto il piano di lavoro.
5. Se la lavastoviglie viene installata all'estremità di una cucina componibile con parete laterale accessibile, rivestire lateralmente la zona delle cerniere (copertura disponibile presso il Servizio Assistenza).
6. Isolare contro l'umidità i bordi dei mobili e dei piani di lavoro (il materiale isolante non è incluso nella fornitura).
7. Non sigillare le fessure tra l'apparecchio e i mobili adiacenti/il piano di lavoro (ad es. con silicone).
8. Tra lo spigolo superiore del pannello in legno e il piano di lavoro deve essere presente uno spazio di almeno 3 mm.
9. Se si impiegano cacciavite elettrici, regolare un basso numero di giri.
10. Il contenuto dell'imballo può essere diverso a seconda del modello della lavastoviglie. ★
11. Al primo impiego verificare la tenuta di alimentazione e scarico dell'acqua.
12. Dopo il montaggio dei pannelli decorativi e dello zoccolo, è necessario verificare prima di aprire la porta se e in quale misura è opportuno ritagliare lo zoccolo (vedere pagina 25-26), per evitare di danneggiarla.
13. Attenzione! Pericolo di lesioni per la presenza di spigoli vivi.
14. L'apparecchio deve essere collegato all'alimentazione dell'acqua utilizzando set di tubi nuovi. Non riutilizzare set di tubi vecchi.
15. A seconda della configurazione dell'apparecchio la valvola magnetica del tubo di carico sarà azionata dalla tensione di linea (vedere ★ ★).

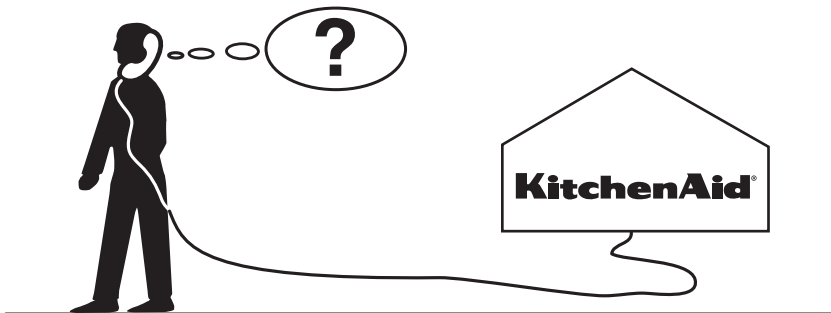
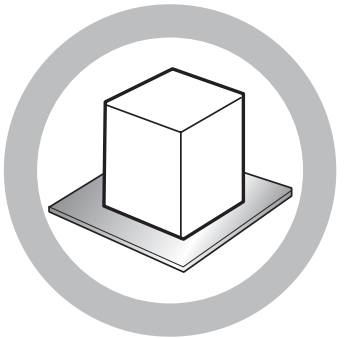
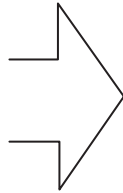
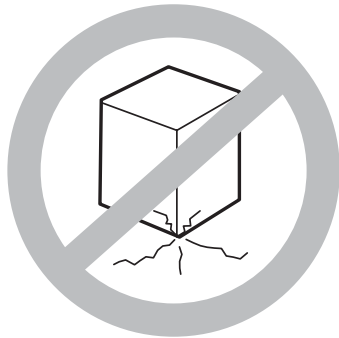
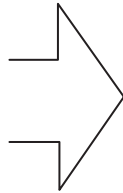
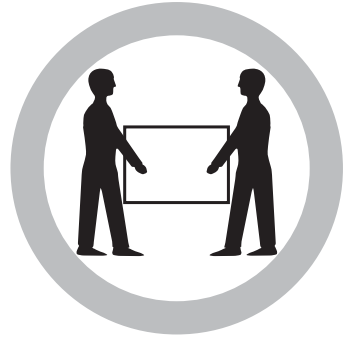
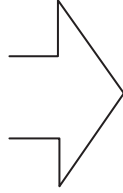

1

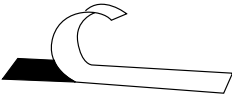

1x

700 x 75 mm

2



2x

300 x 75 mm

3

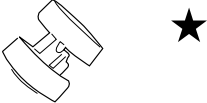

1x

4



2x / 4x

M8

5

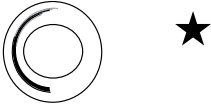

2x / 4x

6

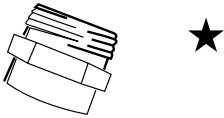

1x

1/2" - 3/4"

7

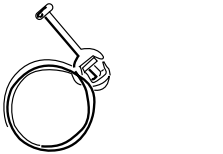

1x

25 - 29 mm

8



6x

3,5 x 16 mm

9



1x

10



8x

4,0 x 10 mm

11



2x

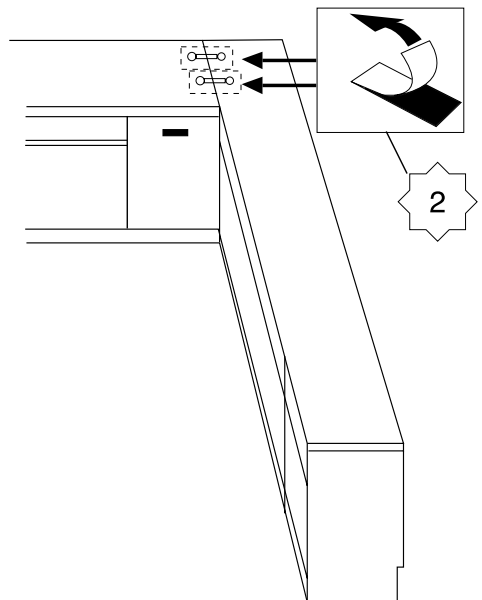
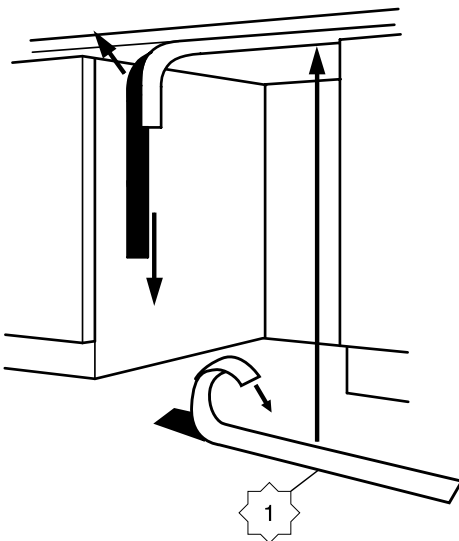
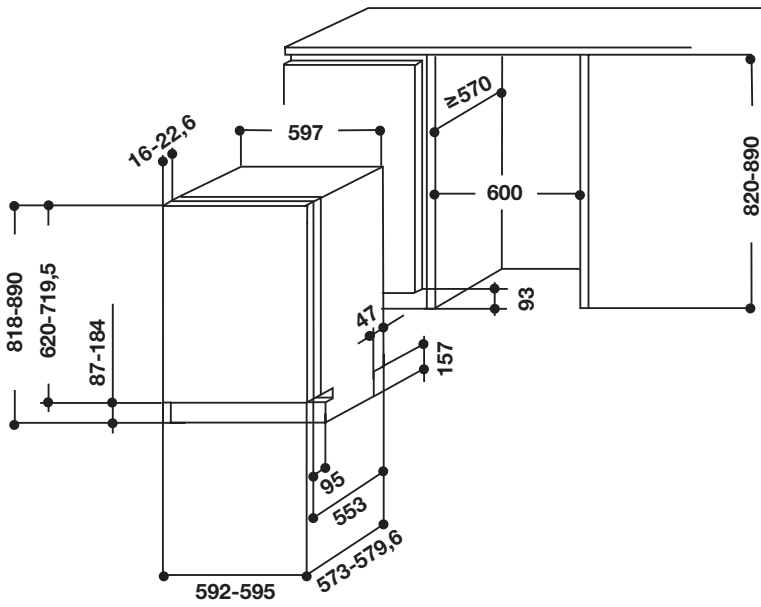

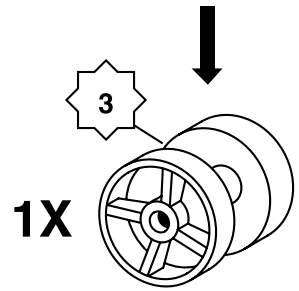
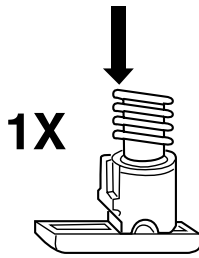
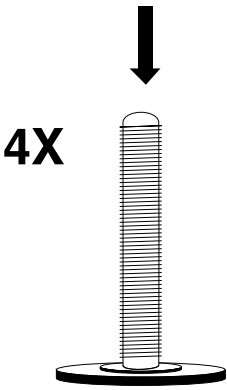
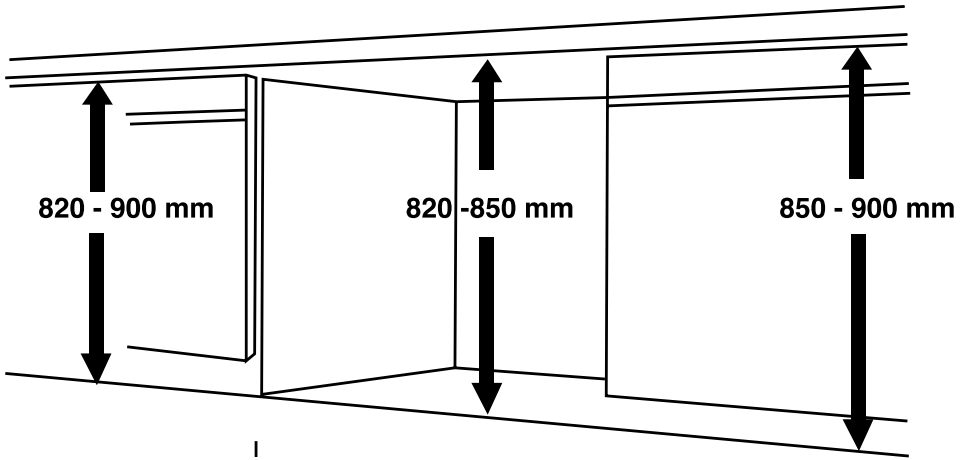

+

+

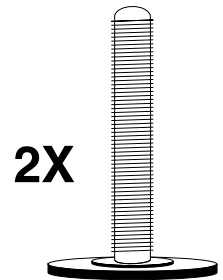
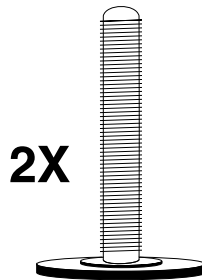

820 - 900 mm

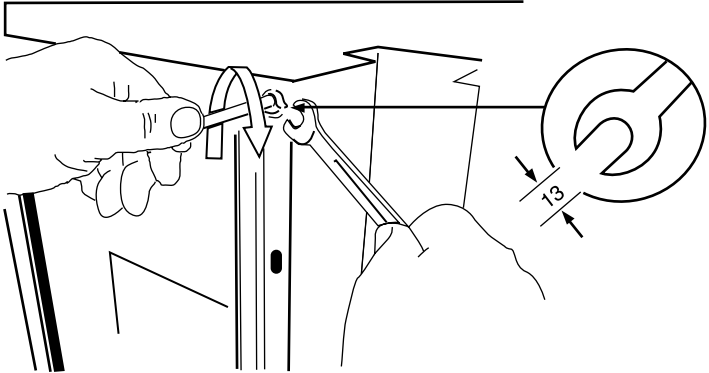
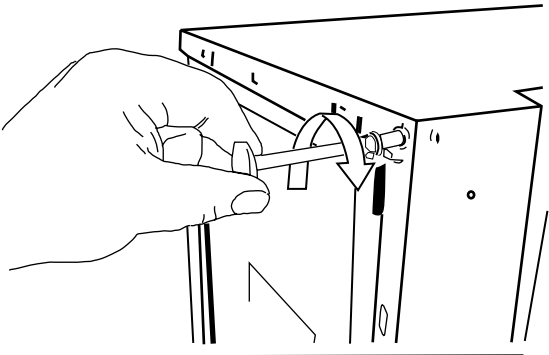
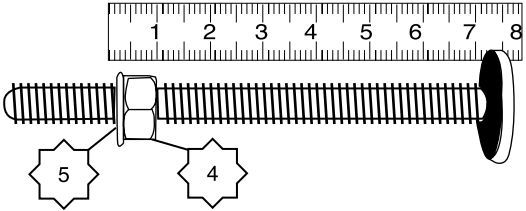
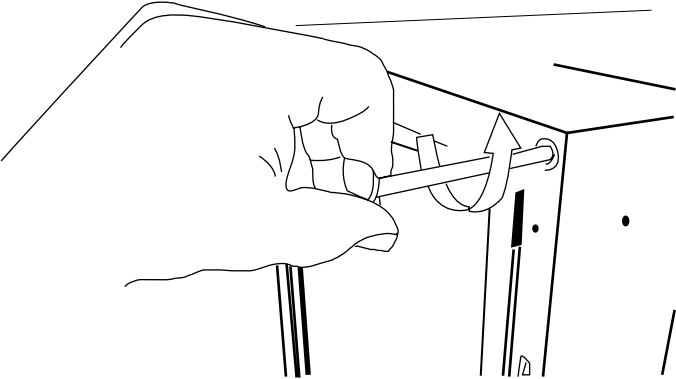

850 - 900 mm

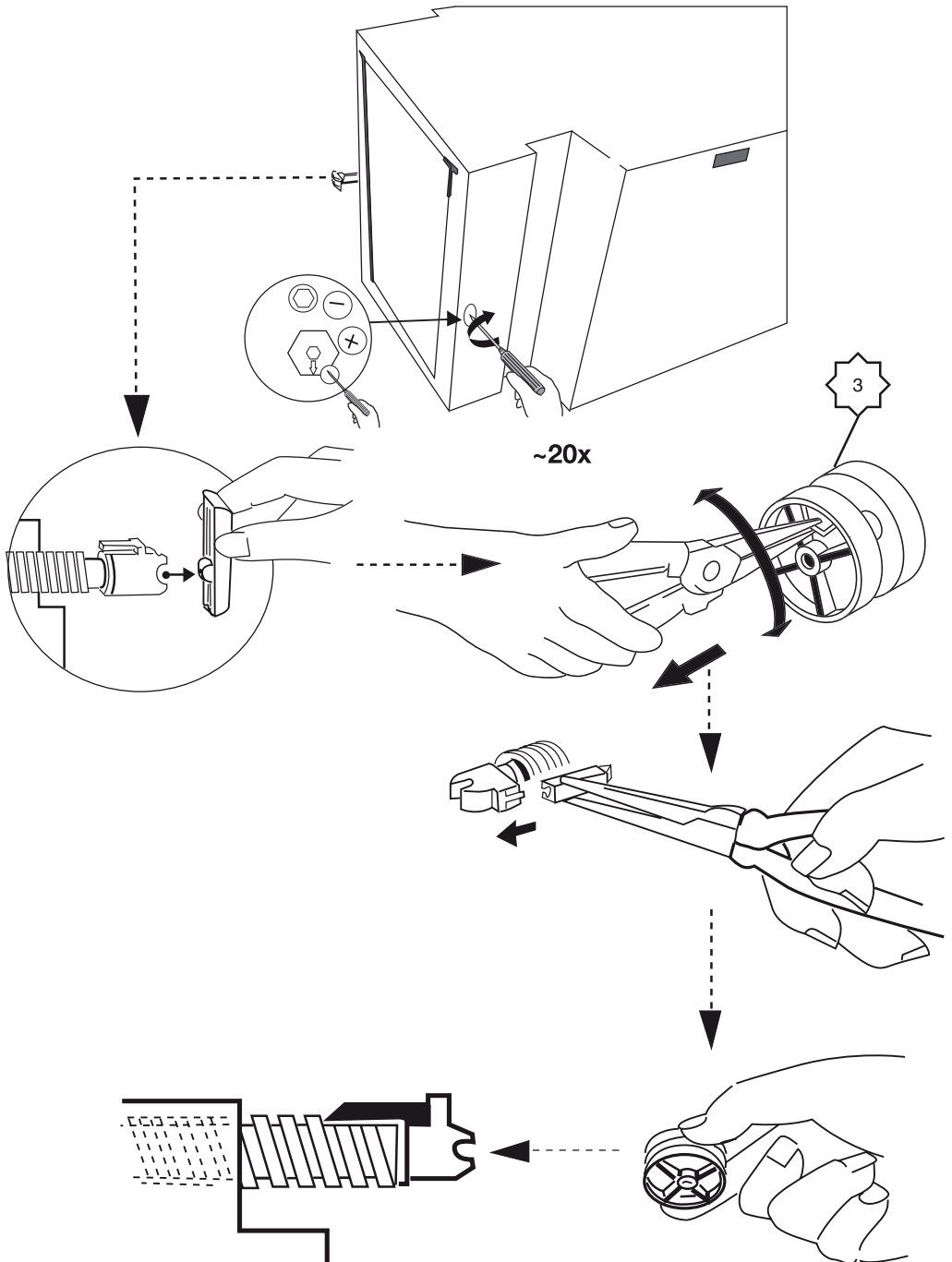



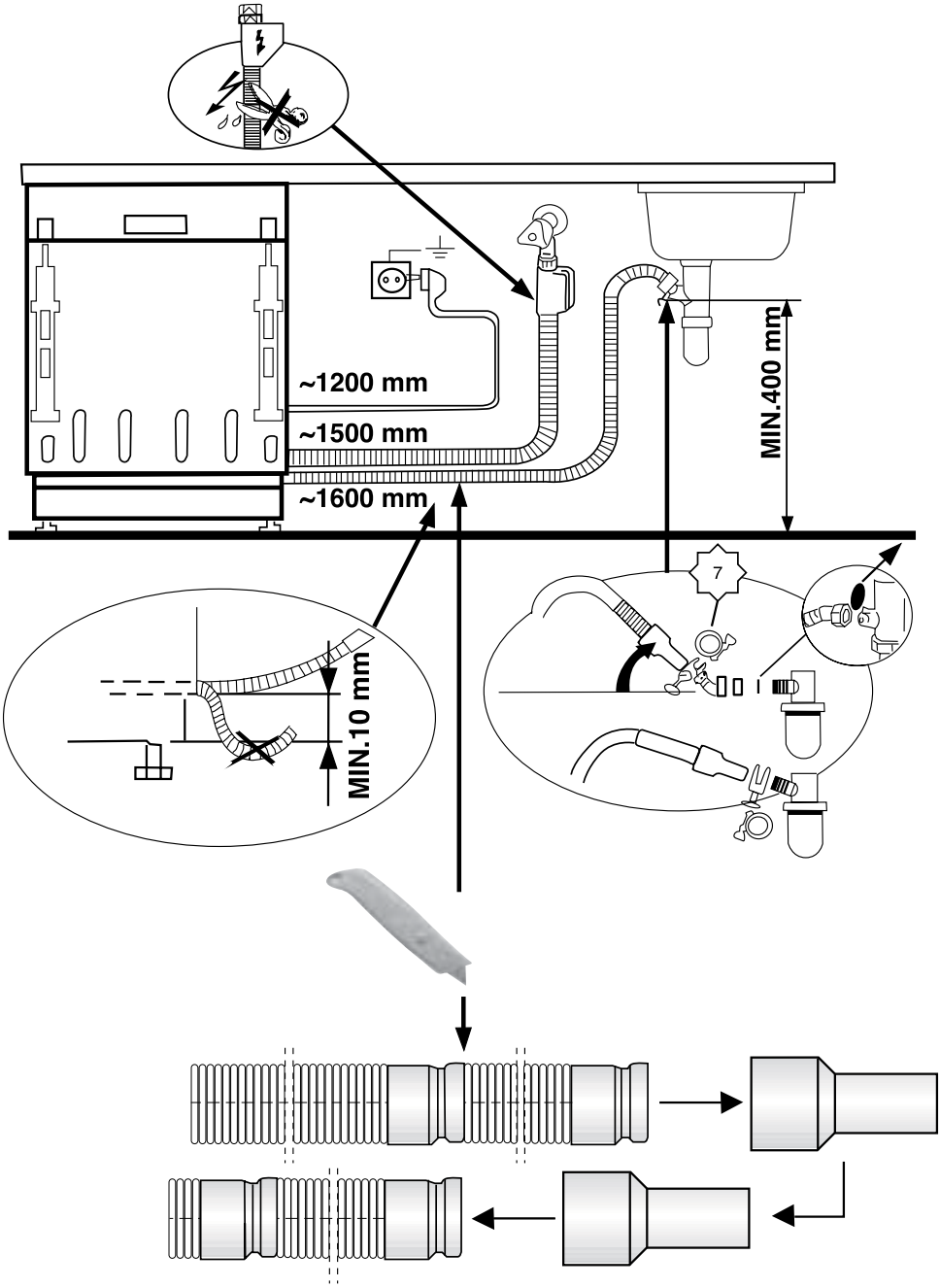

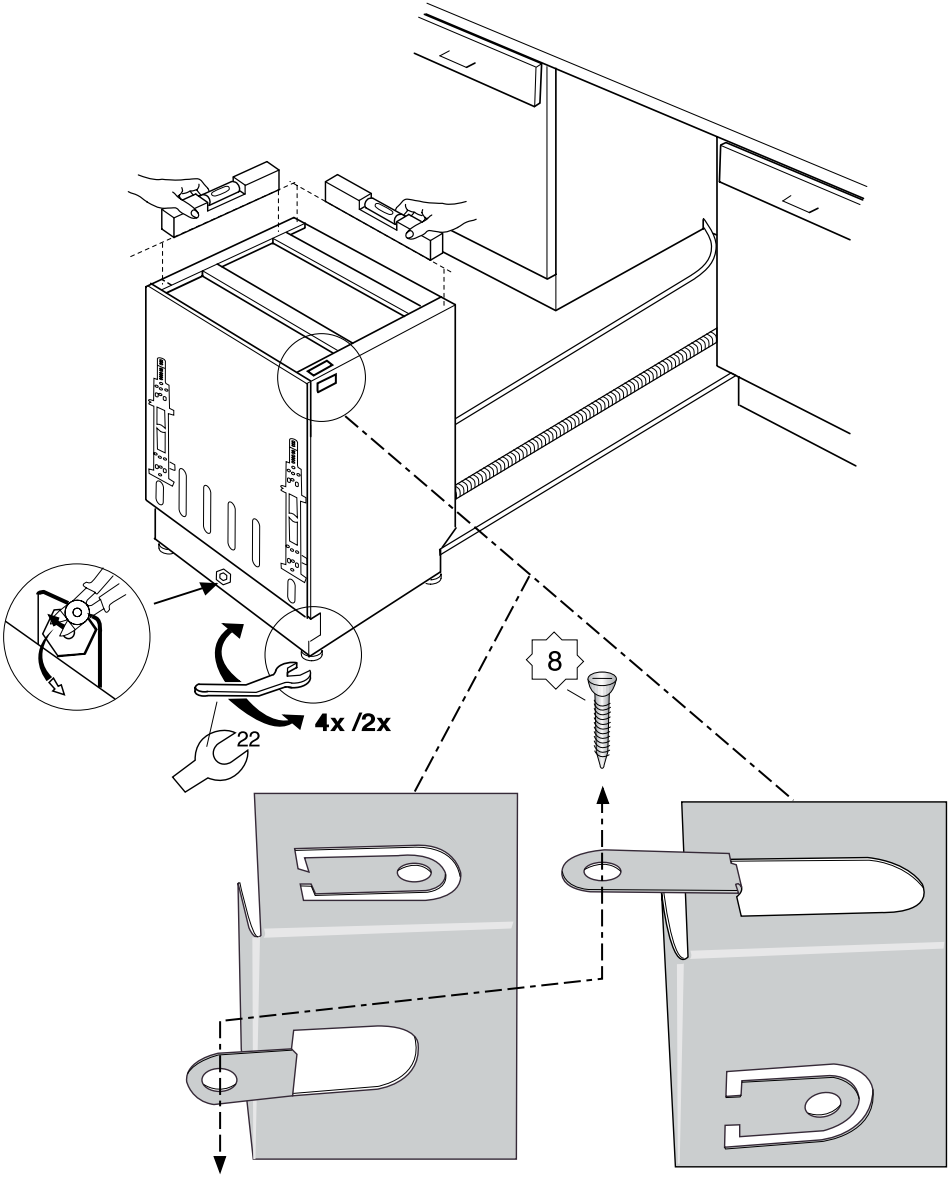

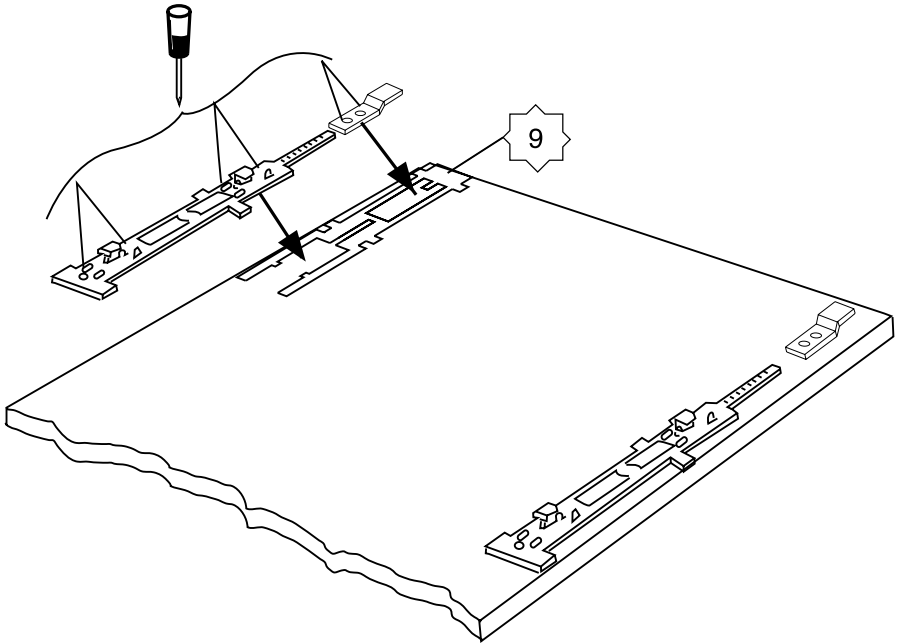
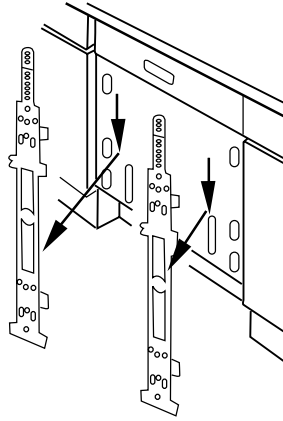
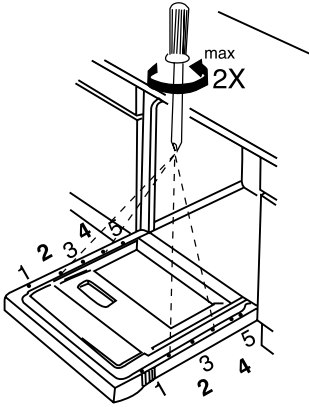

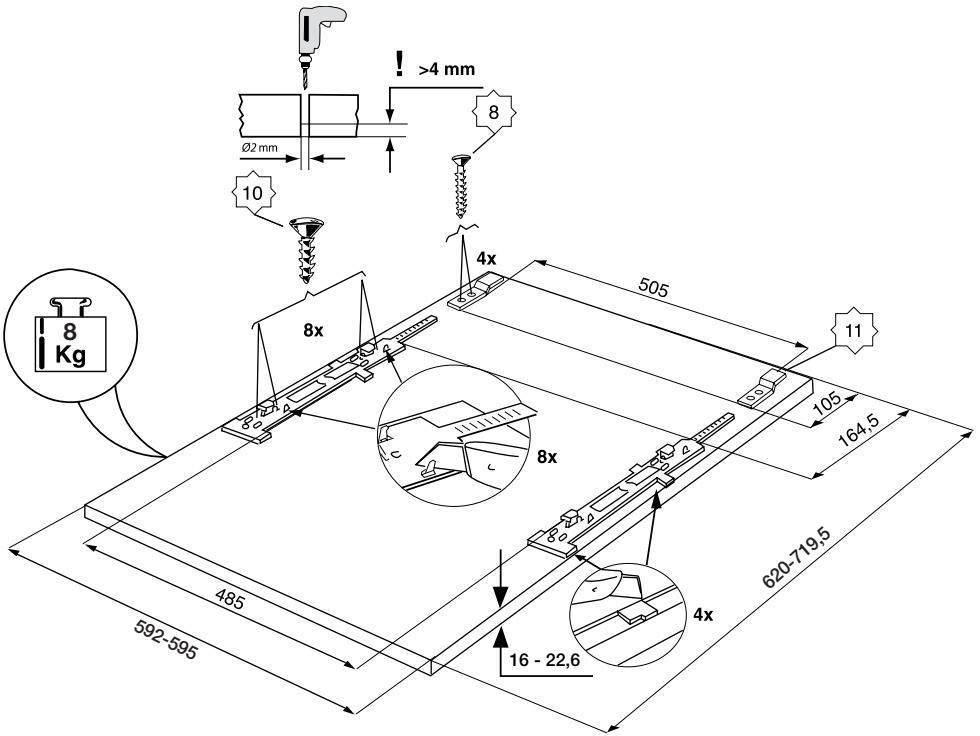

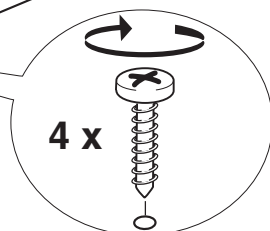
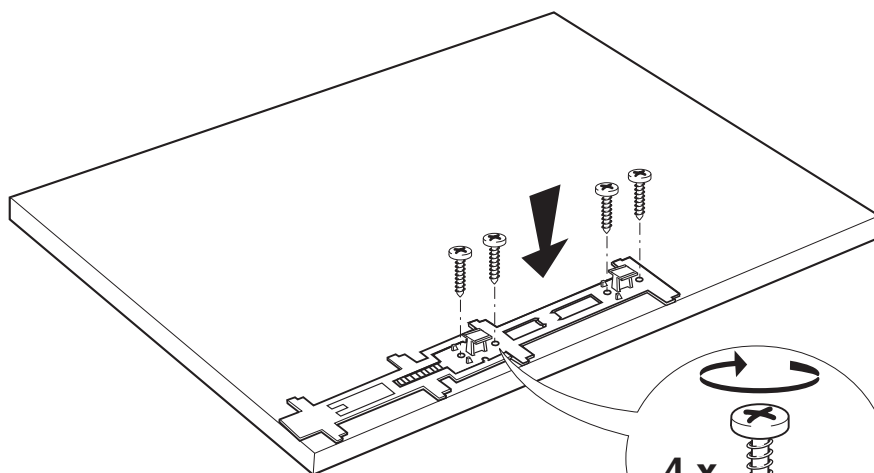
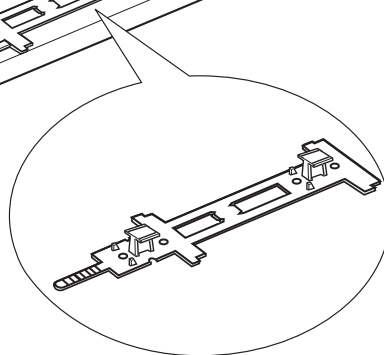
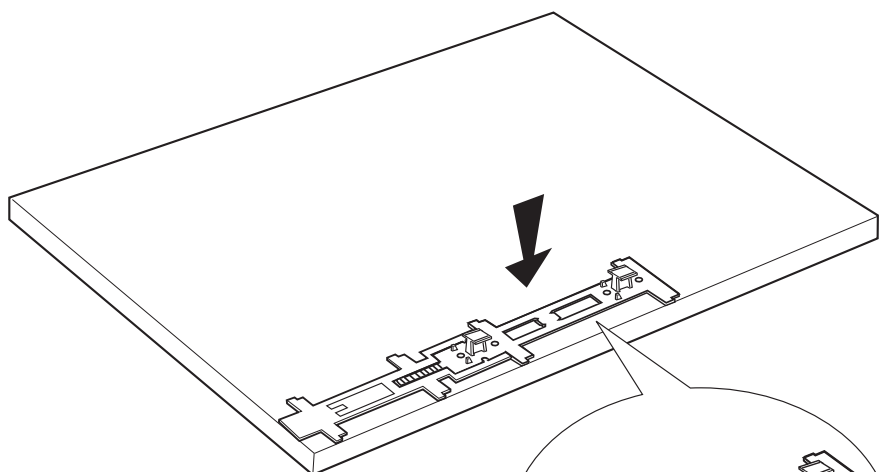

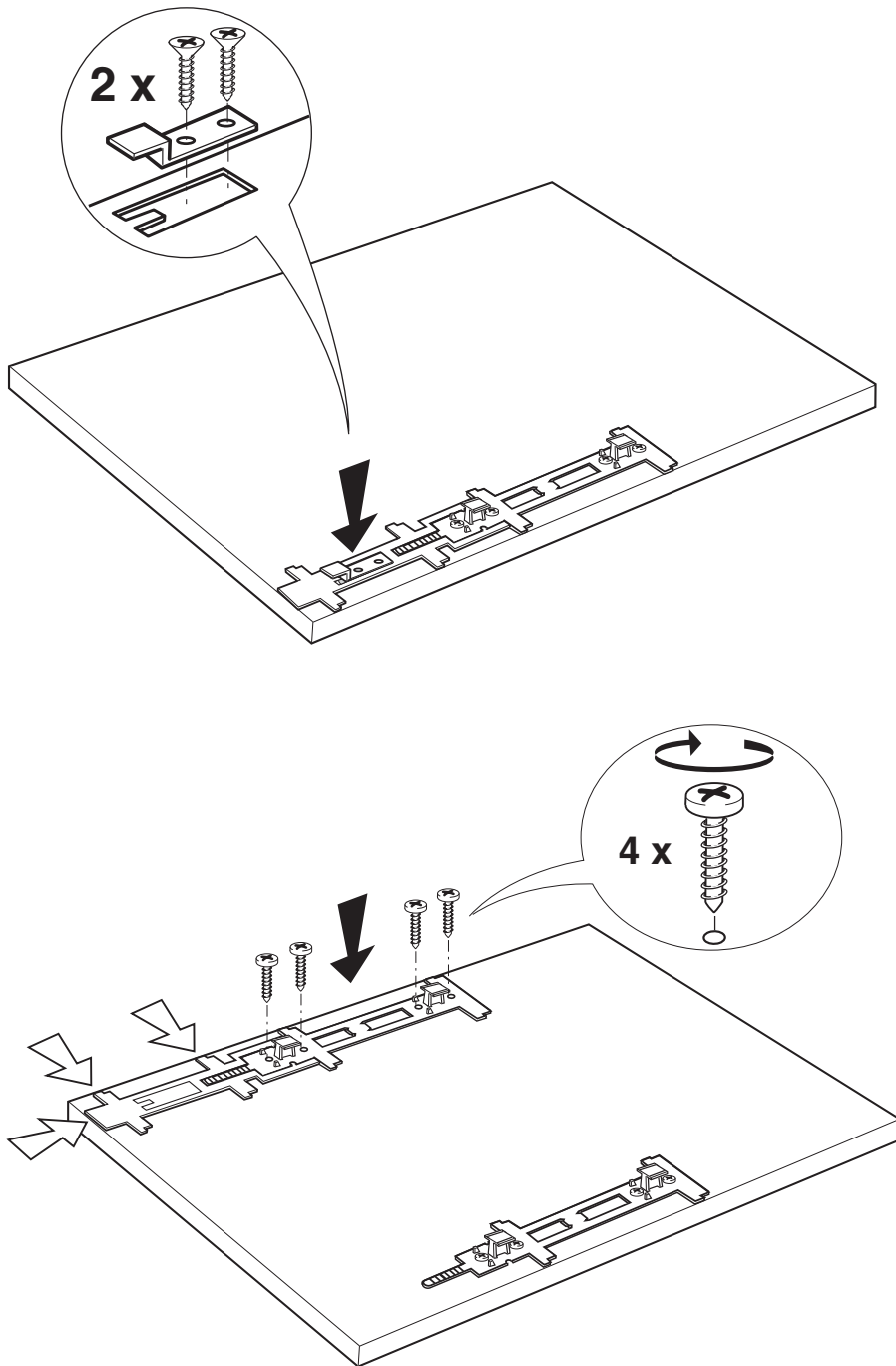

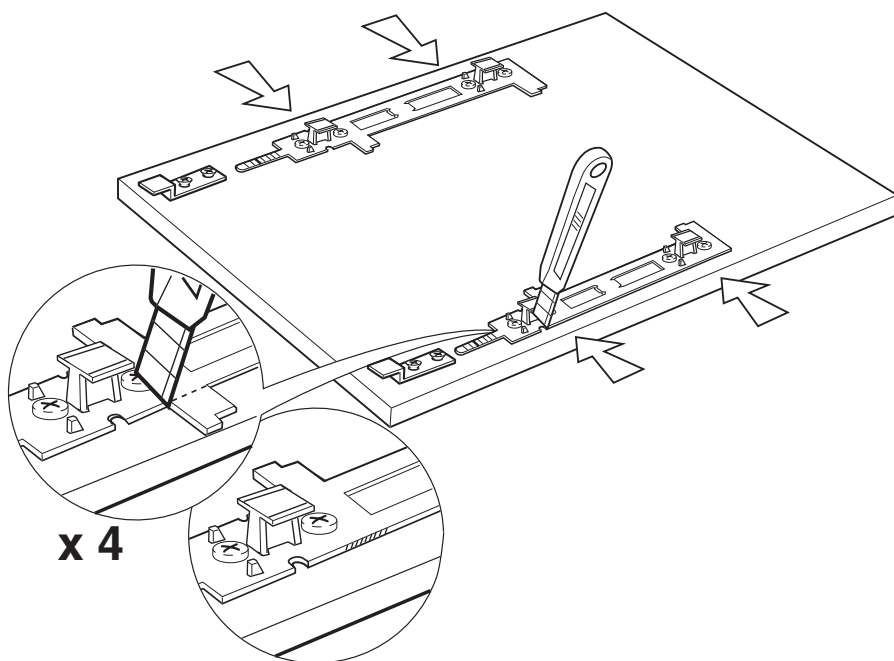
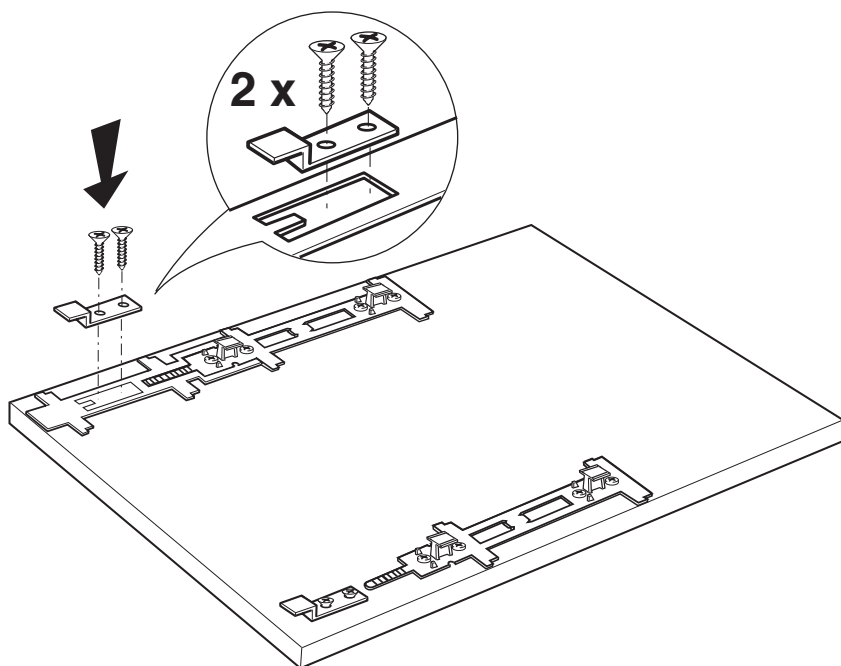

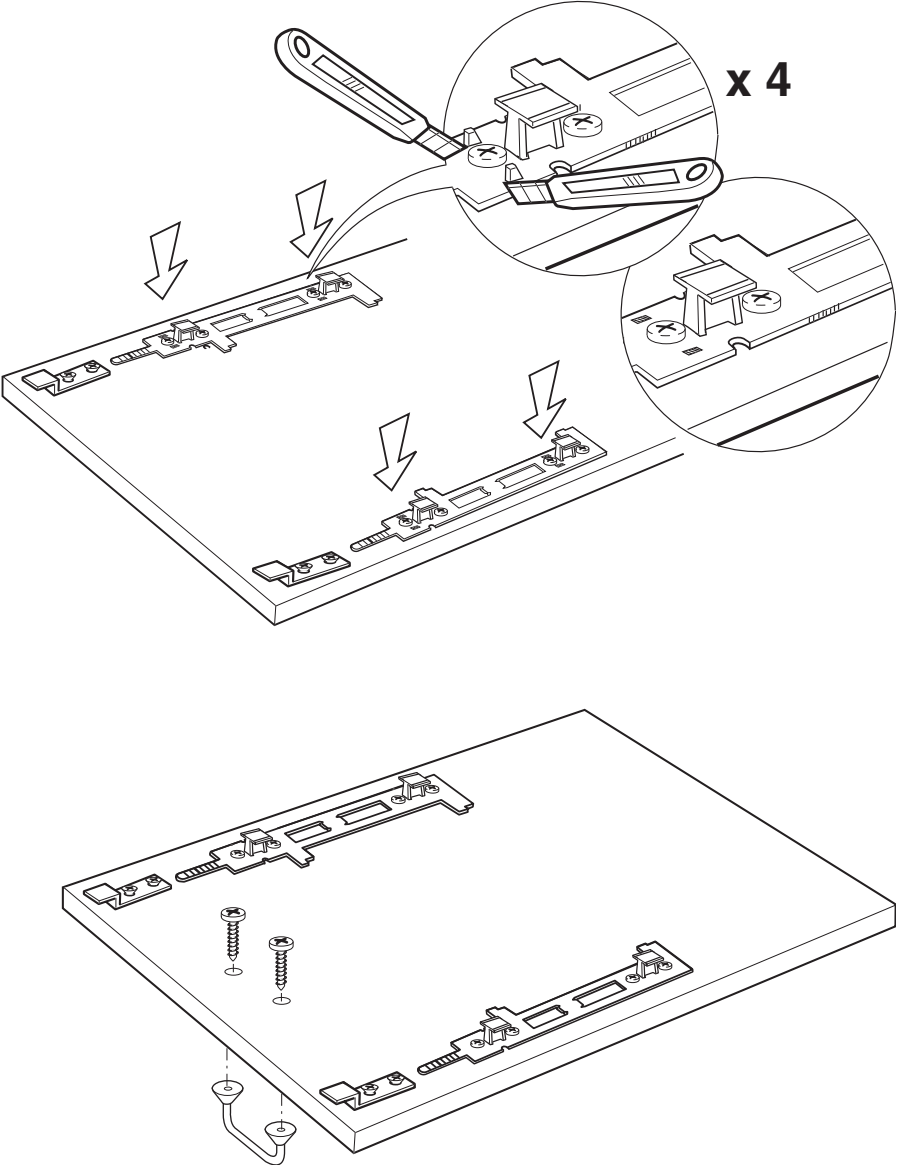

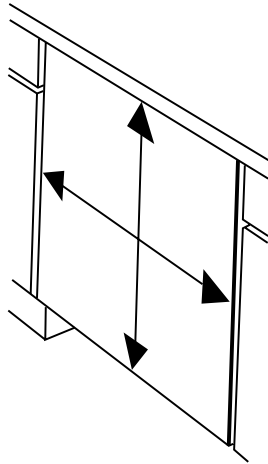
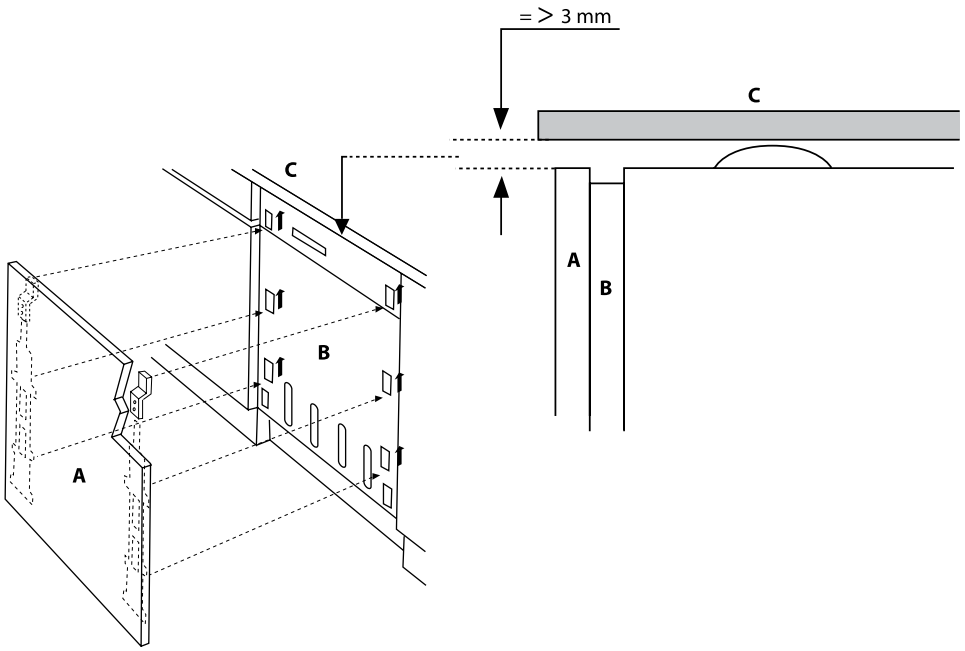

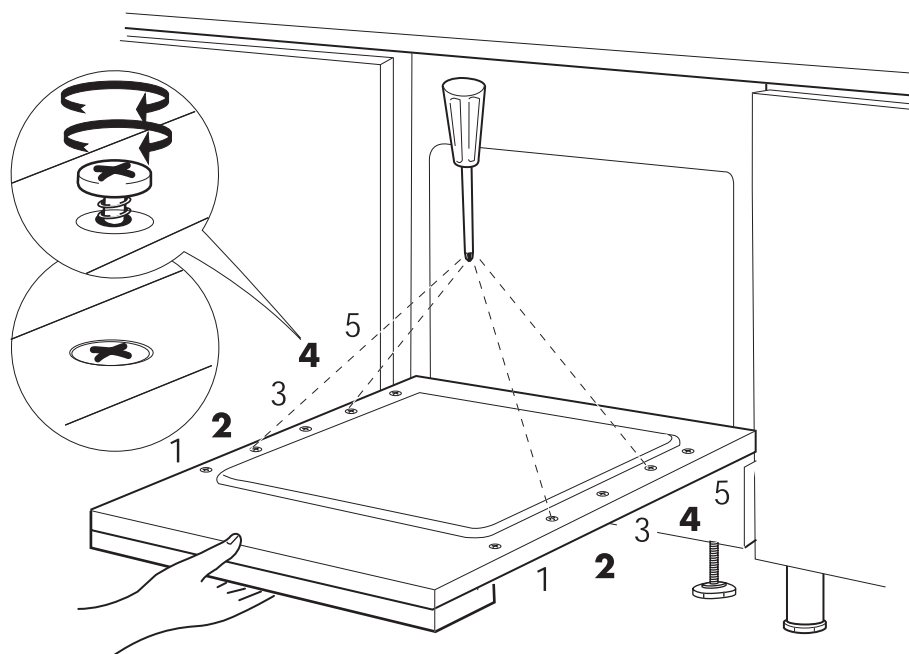
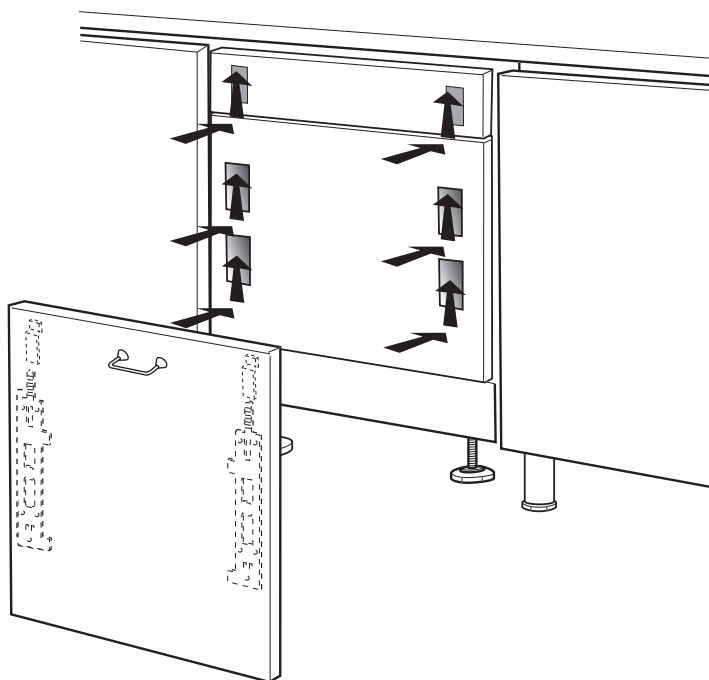

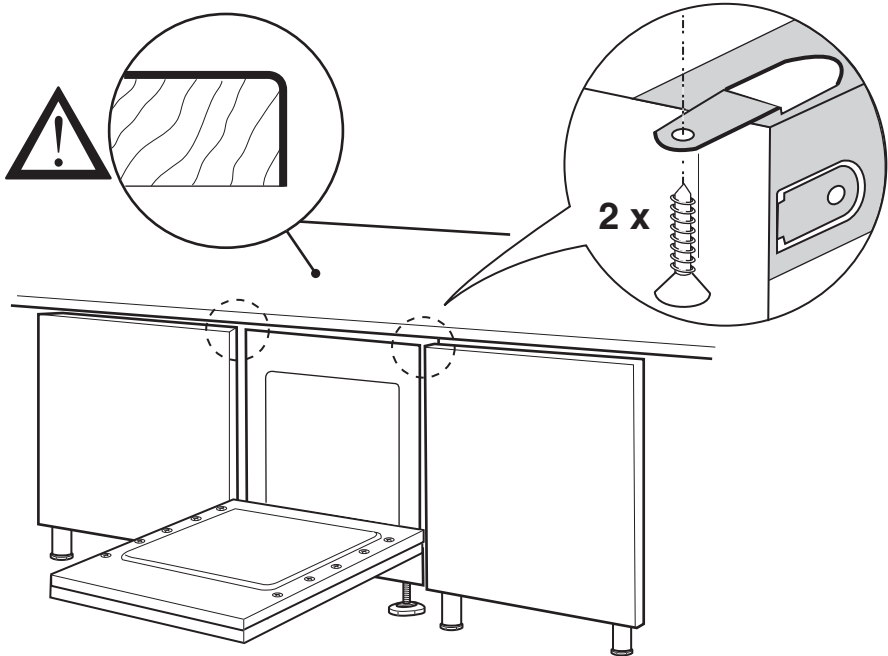
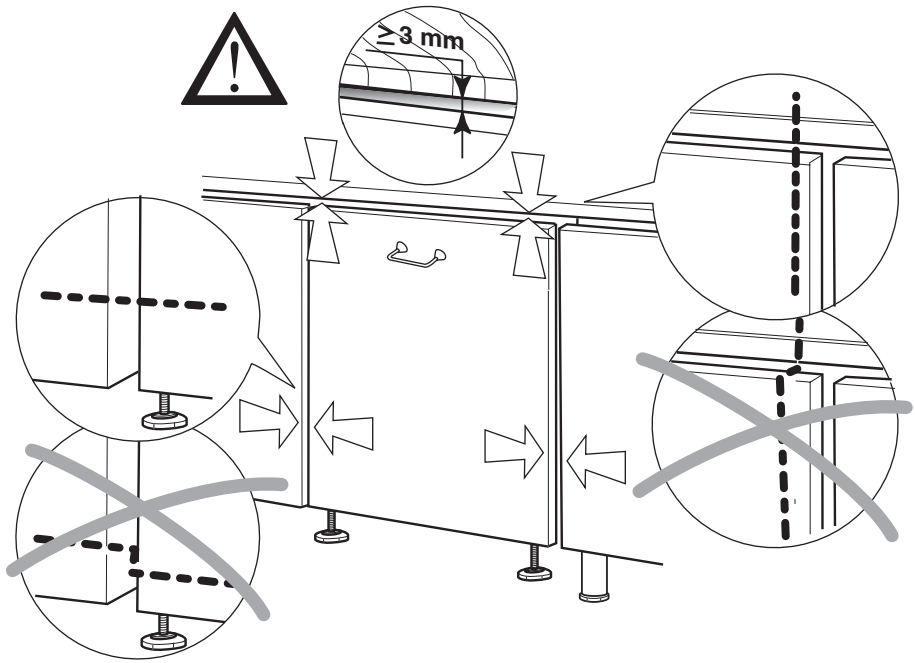

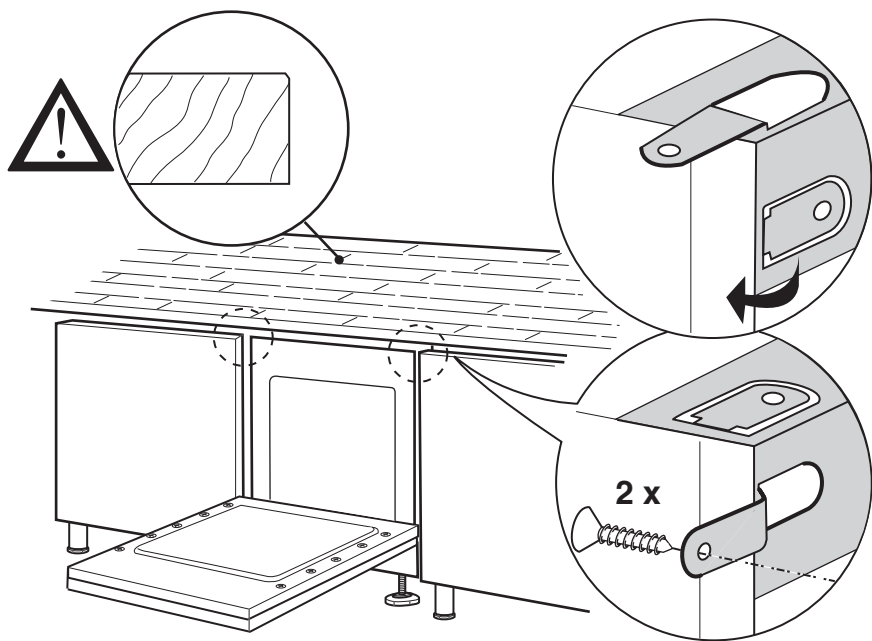
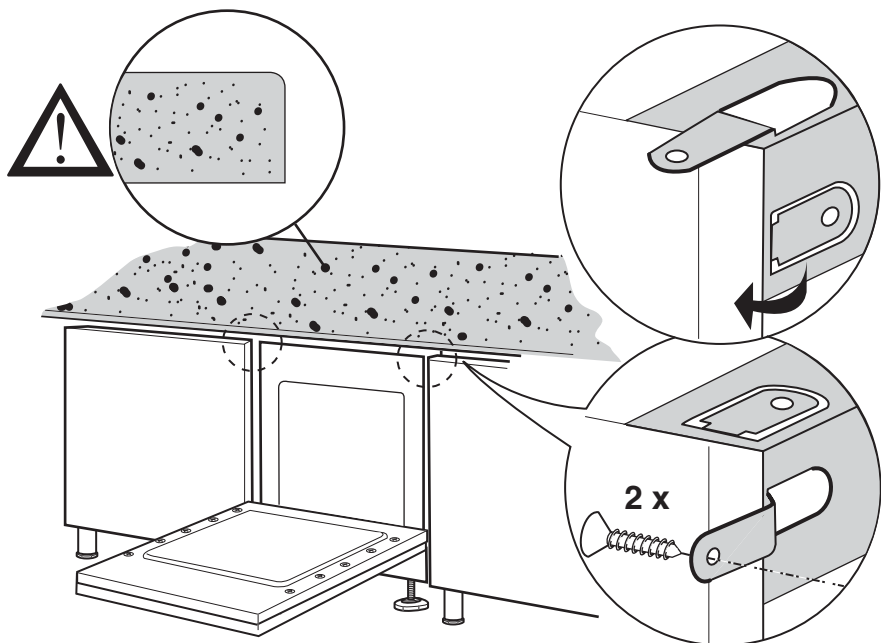

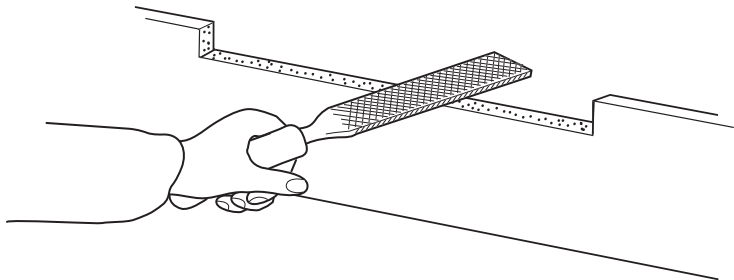
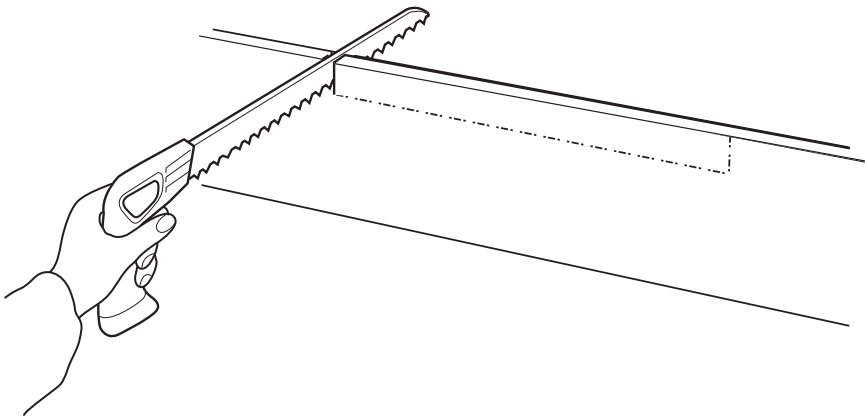
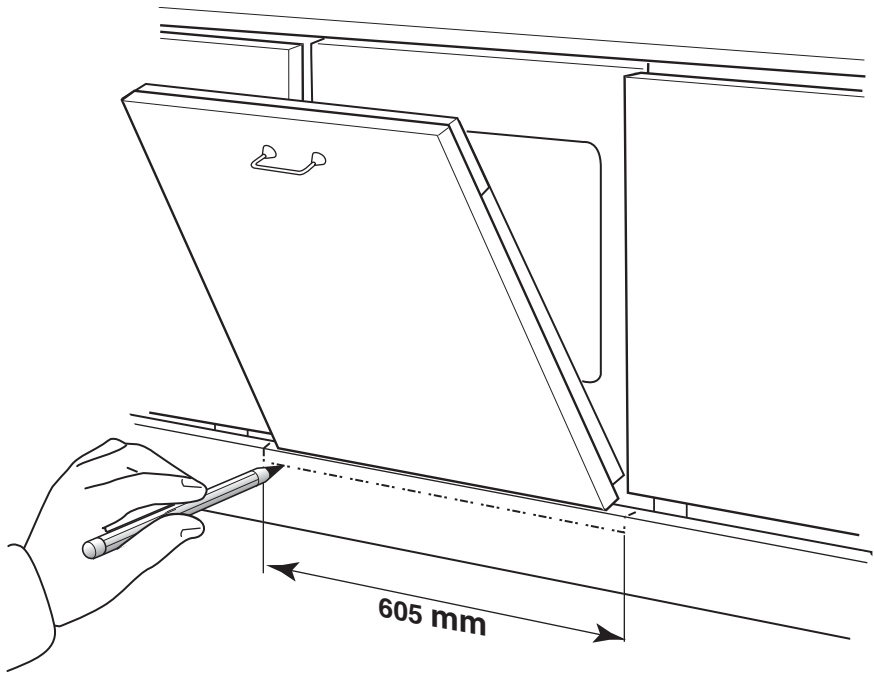

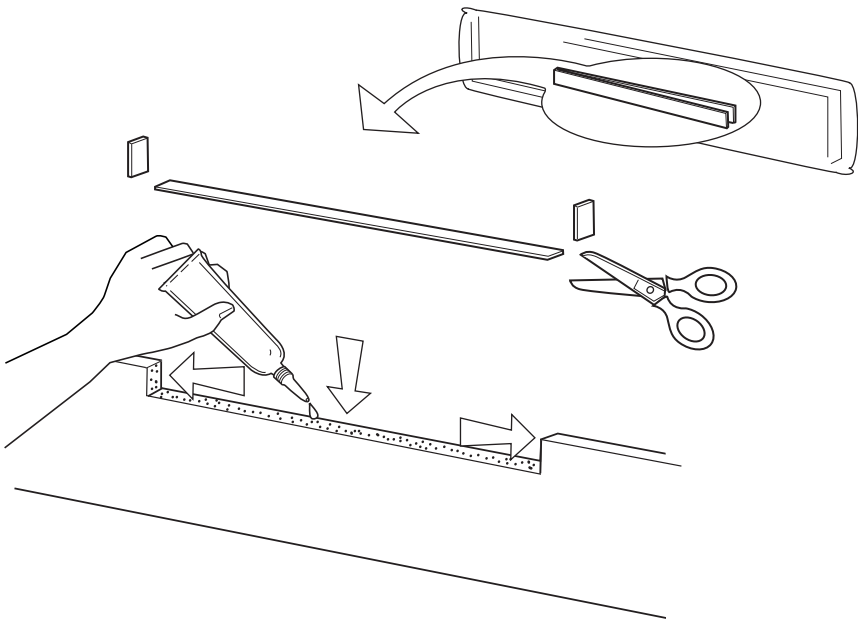
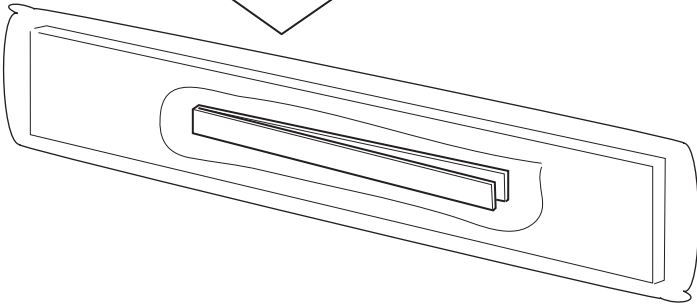
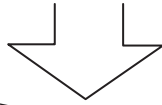
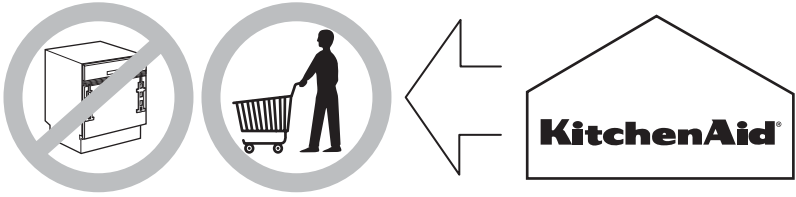

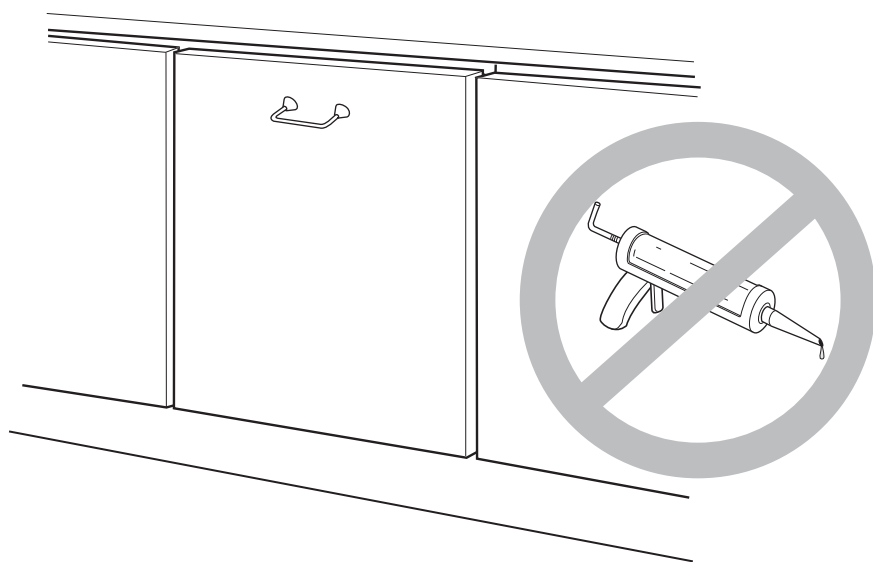
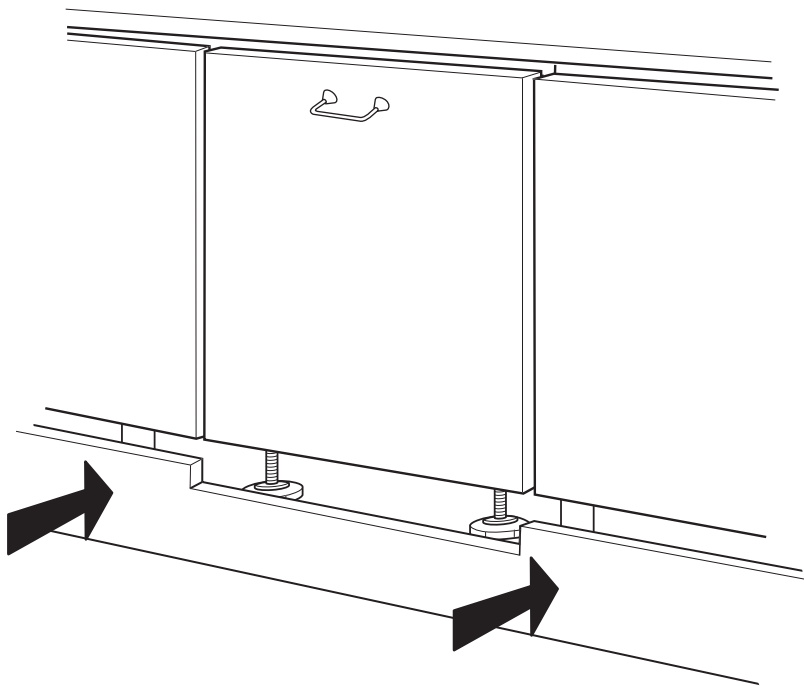

Printed in Italy  
12/07

5019 102 00350



\*BIEN PENSÉ. BIEN FABRIQUÉ.™